



Proposal Number: 285463 SUS-CON CP-IP

Sustainable, Innovative and Energy-Efficient Concrete, based on the Integration of All-Waste Materials

Deliverable D6.4 Demo applications

Author(s) ¹ :	<i>SC Iridex Group Plastic SRL, ACCIONA, ISTON</i>
Date:	<i>M45</i>
Workpackage:	WP6
Distribution ²	PU
Status ³ :	<i>Final</i>
Abstract:	D6.4 reports on the demo applications of the SUS-CON solutions on real buildings. The installation of components and relevant energy efficiency tests on mock-ups in Spain are included. The current status of the activities related to other two mock-ups in Turkey and Romania is also reported, this will be further detailed in D6.6.
File Name	<i>Deliverable D6.4_Demo applications</i>

¹ Just mention the partner(s) responsible for the Deliverable

² PU: Public, RE: restricted to a group specified by the consortium CO: Confidential, only for members of the consortium; Commission services always included.

³ Draft, Revised, Final



TABLE OF CONTENTS

1. Introduction.....	3
2. Description of the mock-ups in Spain: materials and execution.....	5
2.1. Introduction.....	5
2.2. Location of construction.....	8
2.3. Materials used for the construction of the mock-ups.....	11
2.4. Description of the construction process.....	11
2.4.1. Blocks mock-ups.....	11
2.4.2. Panels mock-ups.....	14
2.5. Energy efficiency test results (<i>ongoing tests</i>).....	17
2.5.1. Blocks mock-ups results.....	20
2.5.2. Panels mock-ups results.....	25
2.6. Final considerations.....	29
3. Description of the mock-ups in Turkey and Romania.....	31
3.1. Locations in Turkey and Romania.....	31
3.2. Design of the mockups in Turkey and Romania.....	34
3.3. Materials.....	39
3.4. Final considerations.....	41
4. General conclusions.....	43



1. Introduction

The main objective of WP6 (*PRODUCTION UPSCALE – Demonstration*) is to validate the feasibility of the developed production process of the SUS-CON components and to demonstrate the real improvements in the component performances, with the aim of subsequent industrialization.

More specifically Task 6.2 (*Prototypes design and realization*) is focused on the production of SUS-CON components to be used both for characterization tests (Task 6.3) and for the demo buildings construction (Task 6.4 - *Application on real buildings*).

In Task 6.4, the installation of SUS-CON solutions on real buildings demonstrates the actual applicability of the Project results and the real performances obtainable in terms of energy efficiency. In this regard, three different demo sites have been selected in Europe respectively in Spain (ACCIONA), Turkey (ISTON) and Romania (IRIDEX). In this way it will be also demonstrated that SUS-CON products are easy to install and do not pose any challenges to global applicators. Moreover, specific tests aimed at the monitoring of the performance are expected, these will be applied both on SUS-CON and on traditional buildings to possibly demonstrate the improvements of performances for SUS-CON solutions.

D6.4 is indeed focused on the demo application of some of the developed SUS-CON solutions on real buildings. The production of components (panels, blocks and screeds by MAGNETTI or ISTON) for each demonstrator as well as the construction of them (by ACCIONA, ISTON or IRIDEX) is the object of D6.4.

MAGNETTI is responsible for the production of components to be used for the mock-ups in Spain, while ISTON for the production of components for mock-ups in Turkey and Romania. Currently the activities related to the construction of mock-ups in Spain have been completed and monitoring tests are in progress, while the activities related to the other two mock-ups, in Turkey and Romania, are at their early stage. This is because Turkish regulation does not allow ISTON to import the binders selected for SUS-CON project. Therefore, suitable binders from local sources have been identified and purchased but, before the implementation in the production plant, a series of lab tests were considered necessary and are currently in progress. As a consequence a delay in ISTON's



production occurred and, in turn, the construction the corresponding mock-ups was also delayed. On the other hand, these activities will possibly demonstrate the feasibility to produce construction elements even using raw materials from different sources than those already experimented in the Project.

Taking into consideration these issues it was decided to present the work related to Task 6.4 in two different deliverables, D6.4 and D6.6.

The present report, D6.4, deals with the first installation of SUS-CON products on the mock-ups built in Spain, the monitoring of their thermal and acoustic performances (ongoing tests), also in comparison with traditional components, as well as with the status of the other two mock-ups. The future D6.6 will report on the construction of last two demonstrators, in Turkey and in Romania, and will also include a follow up on monitoring of the SUS-CON mock-ups in Spain. This report will be produced after the completion of the last two demonstrator and however within the end of the Project.

2. Description of the mock-ups in Spain: materials and execution

2.1. Introduction

Within Task 6.4 ACCIONA has carried out the construction of 4 mock-ups in order to demonstrate the feasibility of the SUS-CON products on full scale buildings and their real performance in terms of energy efficiency.

The built mock-ups consist in 4 buildings, 2 made of panel components and 2 made of blocks components. The components of each built mock-up are described below:

- 1 mock-up built with SUS-CON panel components;
- 1 mock-up built with Reference panel components;
- 1 mock-up built with SUSCON blocks components;
- 1 mock-up built with Reference blocks components.

The manufacturing of panels (**Figure 1**, **Figure 2**) and blocks (**Figure 3**) were carried by MAGNETTI Company and shipped to ACCIONA Company.

- Façade panels

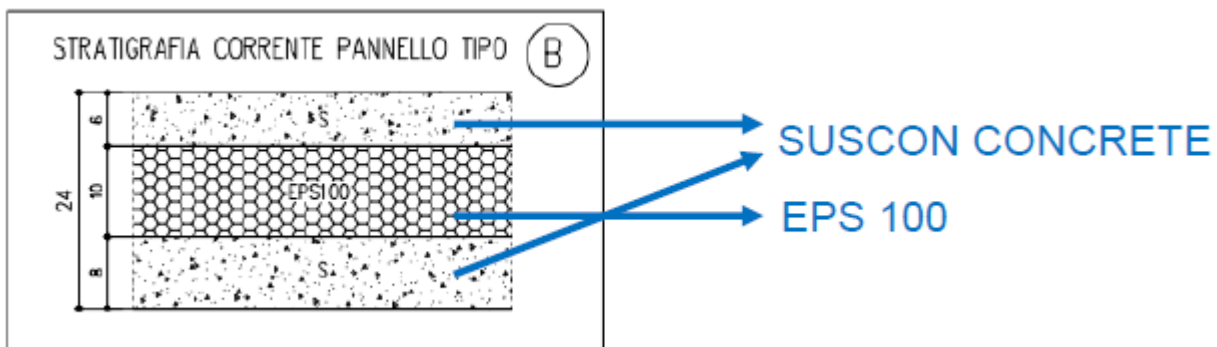

Figure 1: Stratigraphy of SUS-CON façade panel.



1st layer and 2nd layer production.



Metallic reinforcement and positioning of EPS100.



Curing and stocking phases.

Figure 2: Stages of SUS-CON panels production in MAGNETTI's facility.

- Building Blocks

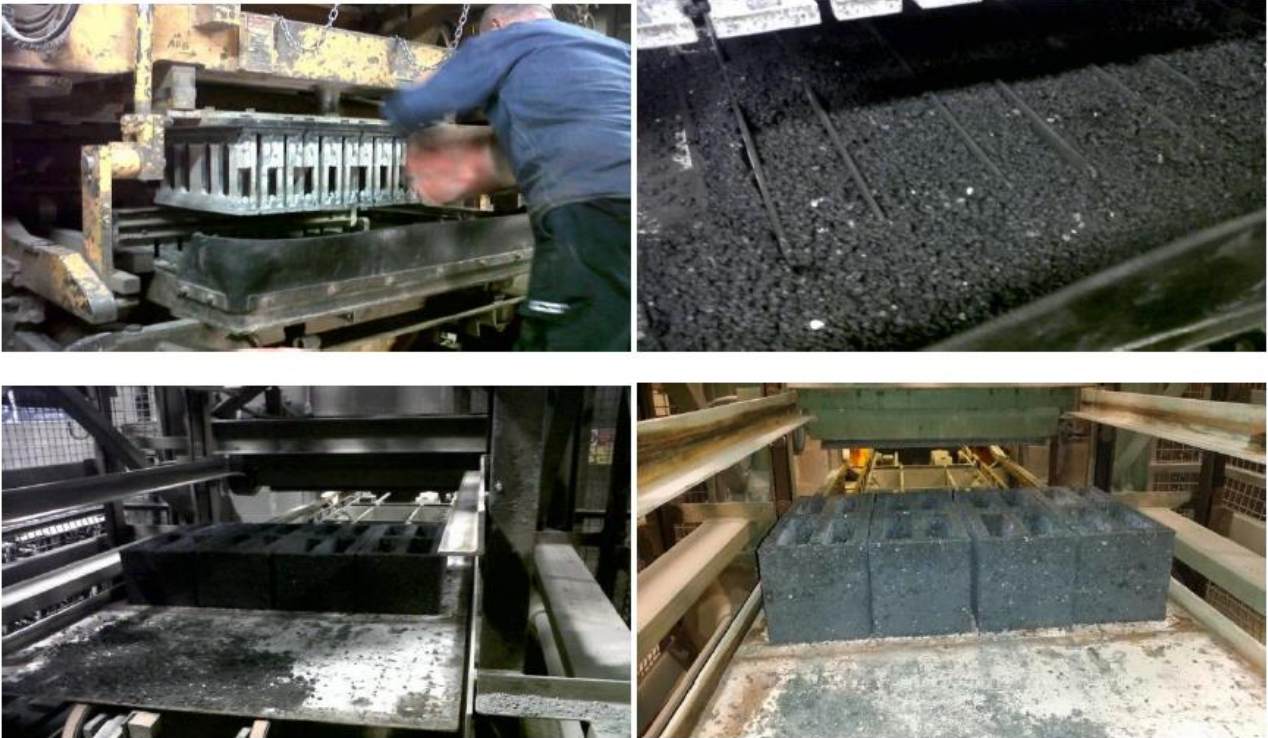

Different phases of blocks production.



Curing rooms and stocking of the blocks.

Figure 3: Stages of SUS-CON building blocks production in MAGNETTI's facility.

The SUS-CON mixtures selected to make the components are respectively PU4 and PU30 for blocks and RX4 for panels. In addition references, panels, made with traditional concretes, have been prepared and also traditional blocks were provided to build the mock-ups.

2.2. Location of construction

The mock-ups were constructed at ACCIONA's Demo-Park (ACCIONA's Central Workshop Facilities) in San Sebastián de los Reyes, Madrid. ACCIONA's Demo-Park has hosted the demonstration activities of up to 14 EC funded projects, related to construction materials and energy efficiency in buildings.

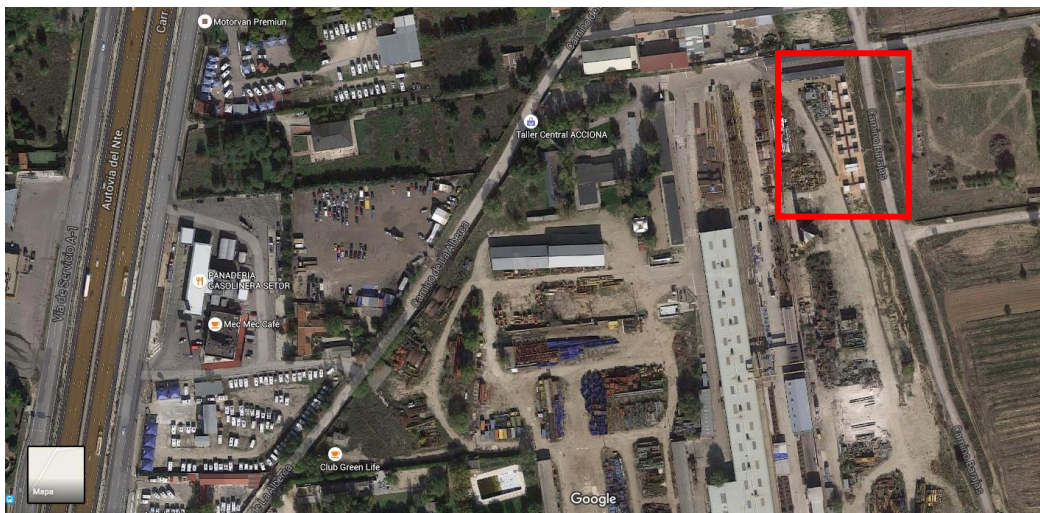

Figure 4: Location of the Demo-Park at ACCIONA's facilities. Google Maps sight.

MAGNETTI has designed the demos for Spain, these are shown in **Figure 5**.

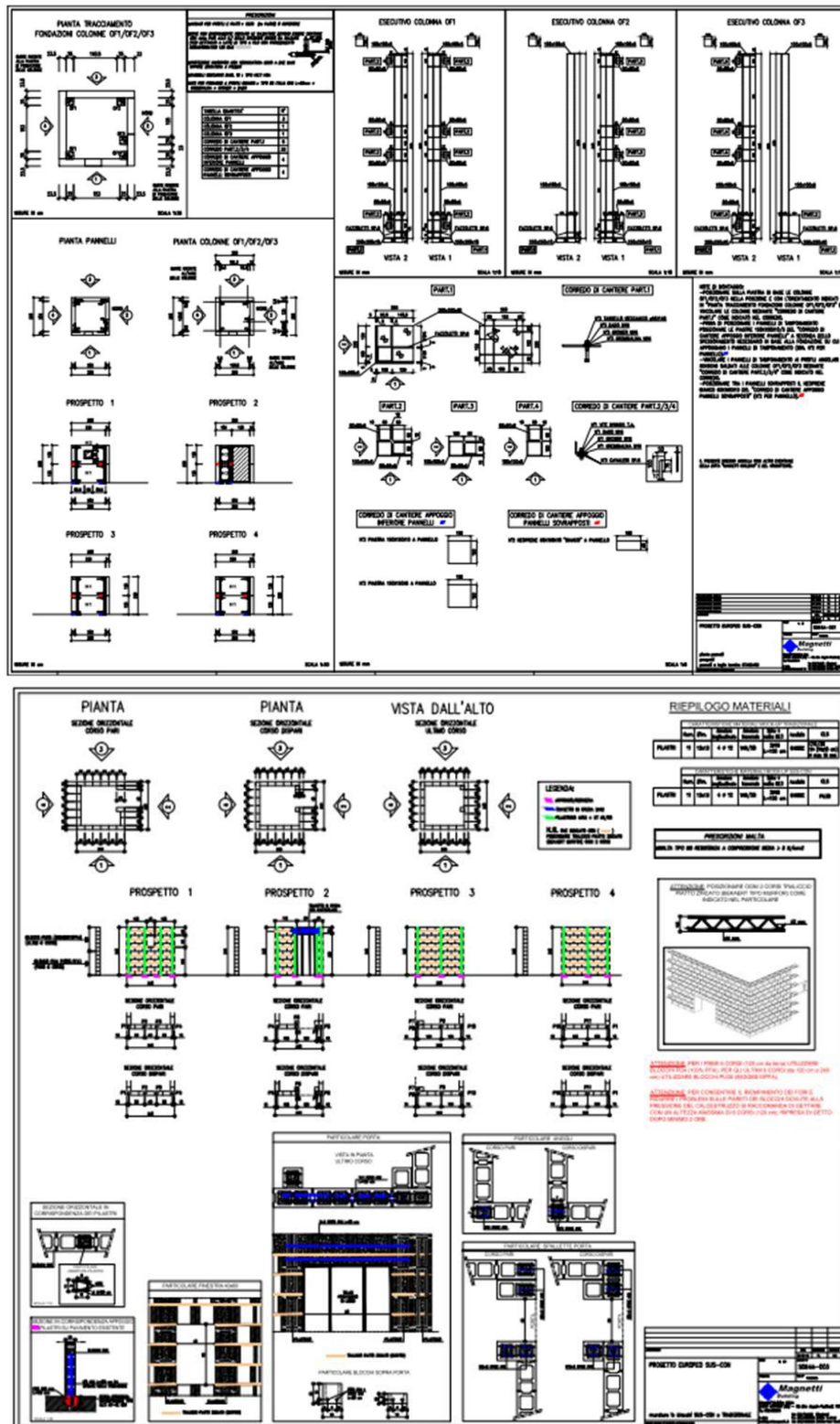

Figure 5: Design of mockups installed in Spain, made with panels (top) and blocks (bottom).

Some specifications regarding the installation of the components in the mockups are shown below.

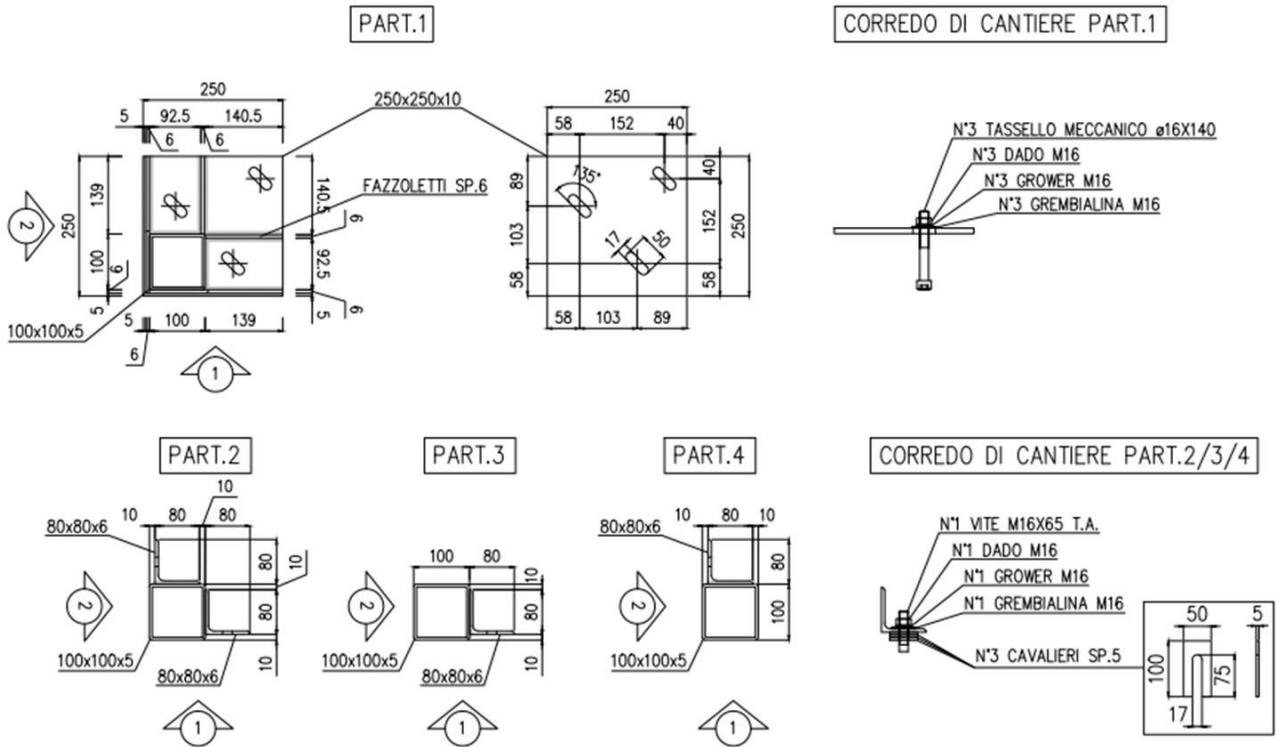

Figure 6: Mockup with panels: joints for assembly.

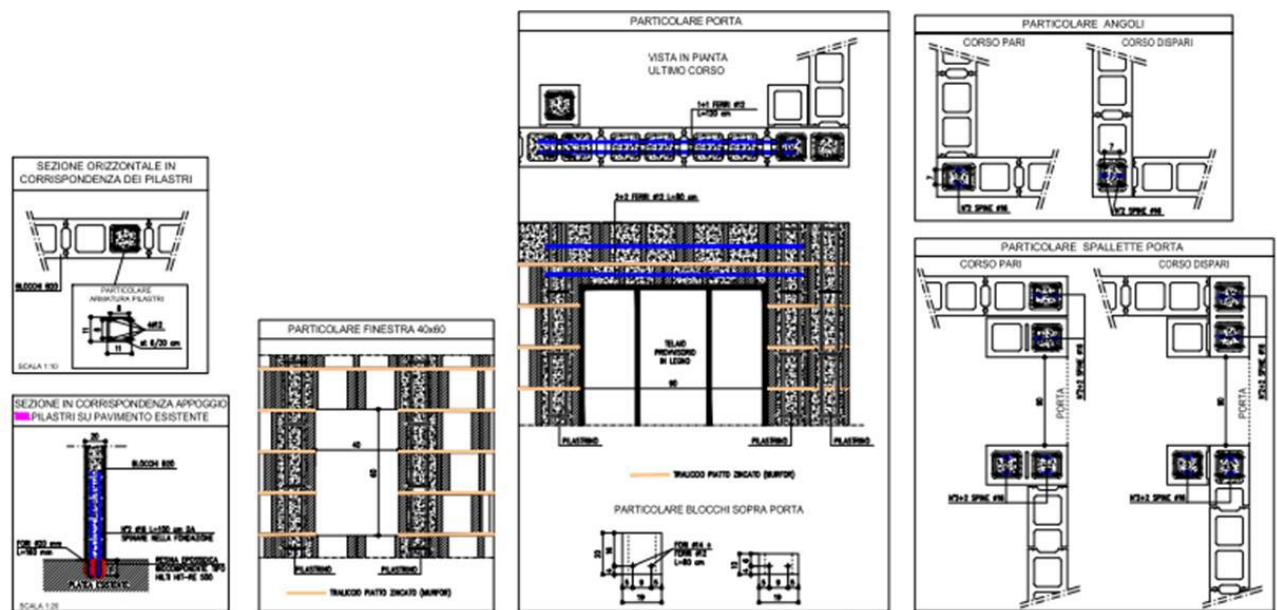

Figure 7: Mockup with blocks: installation requirements.



2.3. Materials used for the construction of the mock-ups

The materials used for the construction of the mock-ups are shown in the following table:

Material	Supplier	Description
Concrete ground slab	Lafarge	MRP-DOS-400 ULTRA SERIES 400 kg of cement/m ³
Metal building frames for the mockups made of panels	Nuvel (SME/metal workshop)	The metal bars were drilled into the ground slab
Roofs	Isolana (SME/insulation company)	The roofs are sandwich panels made of a polyurethane core (5 cm) between two aluminum layers.
Insulation PU foam	Hauser	Expanded PU tubes
Mortar	Sika	Mortar for the joints. Sikaflex
Insulating mortar	Mapei	Mapetherm AR1 GG Gris
Doors and windows	Climalit/Leroy Merlin	Door: 900x2100 mm/ sandwich panels Window: double glass 4/6/4 800x800 mm and 550x550mm
Waterproof paint	Sika	Sikafill grey
Others		Tools, gloves, accessories, etc.

2.4. Description of the construction process

The construction of the mock-ups started on July 7th and finished on August 7th. The ground slabs were prepared to host the mock-ups. Before that, the materials were shipped by MAGNETTI and were received and stored properly by ACCIONA.

2.4.1. Blocks mock-ups

The dimensions of these mockups were finally 2,37 x 2,57 m. In this case, no metal frame was fixed to the ground. Instead of that, pultruded glass fiber rods were placed in the cavities of the first row of blocks.

Two mockups were built, one with traditional concrete blocks and a second one made with PU4 and PU30 blocks; the North (door) and West walls were built with PU4 and the East (window) and South walls were built with PU30.



A polyethylene mesh was placed between adjacent block rows just to fix the mortar among them. Insulating mortar was used to join the blocks together. Every 2 layers of blocks, a metal structure were placed in order to fix the blocks.



Once the most of the blocks are placed, windows, doors and ceilings (PU/Al sandwich panels) were installed.





The internal side of the walls mockups was coated with an insulating mortar and their external side was coated with a regular one.



Figure 8: Mockups built with blocks: SUS-CON (right) and traditional ones (left).

2.4.2. Panels mock-ups

The dimensions of the mockups were chosen to be 2.5 m each side, provided with a door, a window and power supply. The doors were located in the north face and the windows in the east face of the mockups. In the case of the mockups made with panels, the idea was to set a metallic frame on a ground slab that could hold the panels and the rest of the constructive elements: door, window and roof.

Two mockups were built: the SUS-CON one made with RX4 panels and the reference one made with traditional concrete panels.

The metallic frames were transported to ACCIONA's facilities and used in order to align the precast panels. After that, they were anchored to the ground slab with screws drilled on the slab.



Both types of panels were set up forming 2 mockups, the SUS-CON one and the reference one.



Figure 9: Mockups built with panels: SUS-CON panels (front) and traditional panels (back).

In order to eliminate the thermal bridges, PU foam was used to fill the gaps between panels. Then, other constructive elements such as the doors, windows, etc. were installed.



In order to fix the sandwich panels, four metal bars in each mock-up were welded to the metallic structure. In each case, the voids around the door were filled with blocks: PU4 and traditional blocks, respectively.



The ceilings composed of sandwich panels were installed. The blocks around the doors as well as the gaps between the panels and the ceiling were coated with insulation mortar.



In the last step, power supply was installed and the mockup made of SUS-CON panels was coated with a waterproof grey paint in order to protect it from carbonation. In order to ensure a proper comparison, the reference mockup was also painted.



2.5. Energy efficiency test results (ongoing tests)

The parameters measured in the four mock-ups were the followings:

- indoor temperature of the mockups;
- indoor temperature on the walls of the mock-ups;
- external temperature;
- external temperature on the walls of the mock-ups;
- heat flux within the walls of the mock-ups.

The windows were covered with a reflective aluminum layer in order to avoid direct irradiation on the probes and therefore overheating.



In order to monitor the mockups, several probes were installed:

- two probes for indoor temperature (T1, T2);
- one temperature probe for indoor temperature on the walls (T3);
- one heat flux probe on the south wall (T5);
- one temperature probe for external temperature (T8);
- one temperature probe for external temperature on the walls (T9).

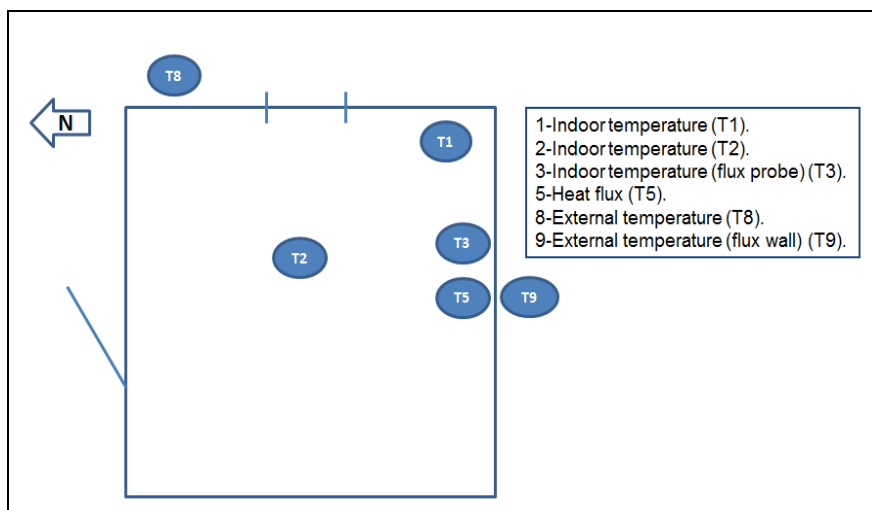

The probe used for the heat flux measurements are Hukseflux HFP01 heat flux sensors. When heat is flowing through the sensor, the filling material acts as a thermal resistance. Consequently, the heat flux will vary with the temperature gradient across the sensor ΔT ,

which will create a hot side and a cold side. The HFP is a thermopile sensor, i.e. a collection of thermocouples. Each thermocouple has two conductors, of dissimilar metals, which will generate an output voltage V in the mV range that is proportional to the ΔT between the junction of the two conductors, which, in the case of type-T thermocouple, are copper-constantan and copper-copper. This ΔT is proportional to the heat flux (\emptyset), and follows in the linear law:

$$\emptyset = V/E$$

where E is the calibration constant of the sensor (in $\mu\text{V}/\text{Wm}^{-2}$). To turn the measured voltage V into an understandable heat flux \emptyset in W/m^2 , the output voltage is divided by the calibration constant. The output information then is a scalar in W/m^2 with its sign, following the criterion shown in **Figure 10**.

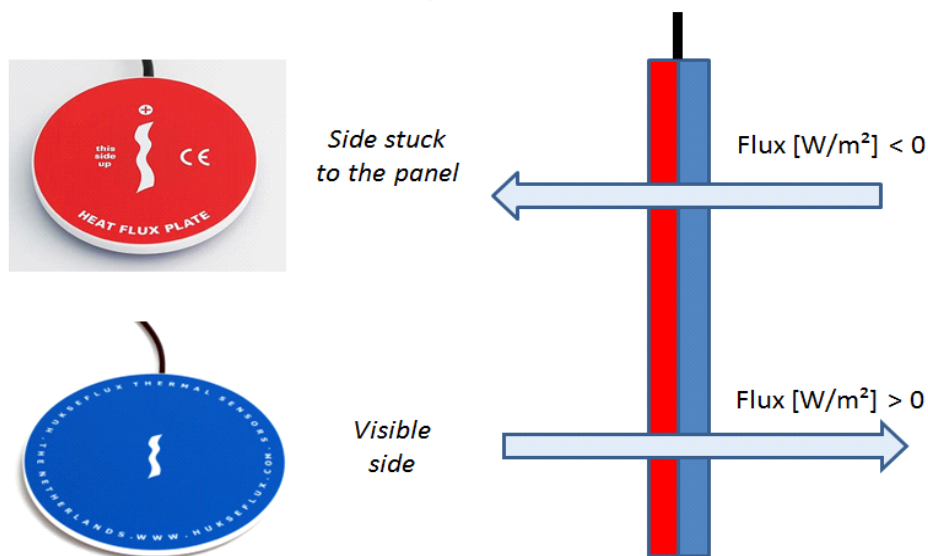

Figure 10: Heat Flux Plate scheme.

For this application, the sensor HFP01 is simply mounted on the object of interest, e. g. the wall panel under test. According to Hukseflux, the sensor manufacturer, under favorable conditions, the accuracy of heat flux sensors is estimated to be +3/-3%.

The monitoring results presented in this report, D6.4, correspond to the values recorded for 34 days (August/September 2015), further data related to monitoring will be reported in

D6.6. In order to analyze the energy efficiency of the built mock-ups, different charts of temperature versus time and different charts of heat flux versus time were realized. Some gaps are observed in the charts because the power went out and some data were missed. The monitoring results of the panels and blocks mock-ups are shown in sections 2.5.1 and 2.5.2.

2.5.1. Blocks mock-ups results

- Chart of indoor temperature (T2) in the reference blocks and SUS-CON blocks mockups versus time:

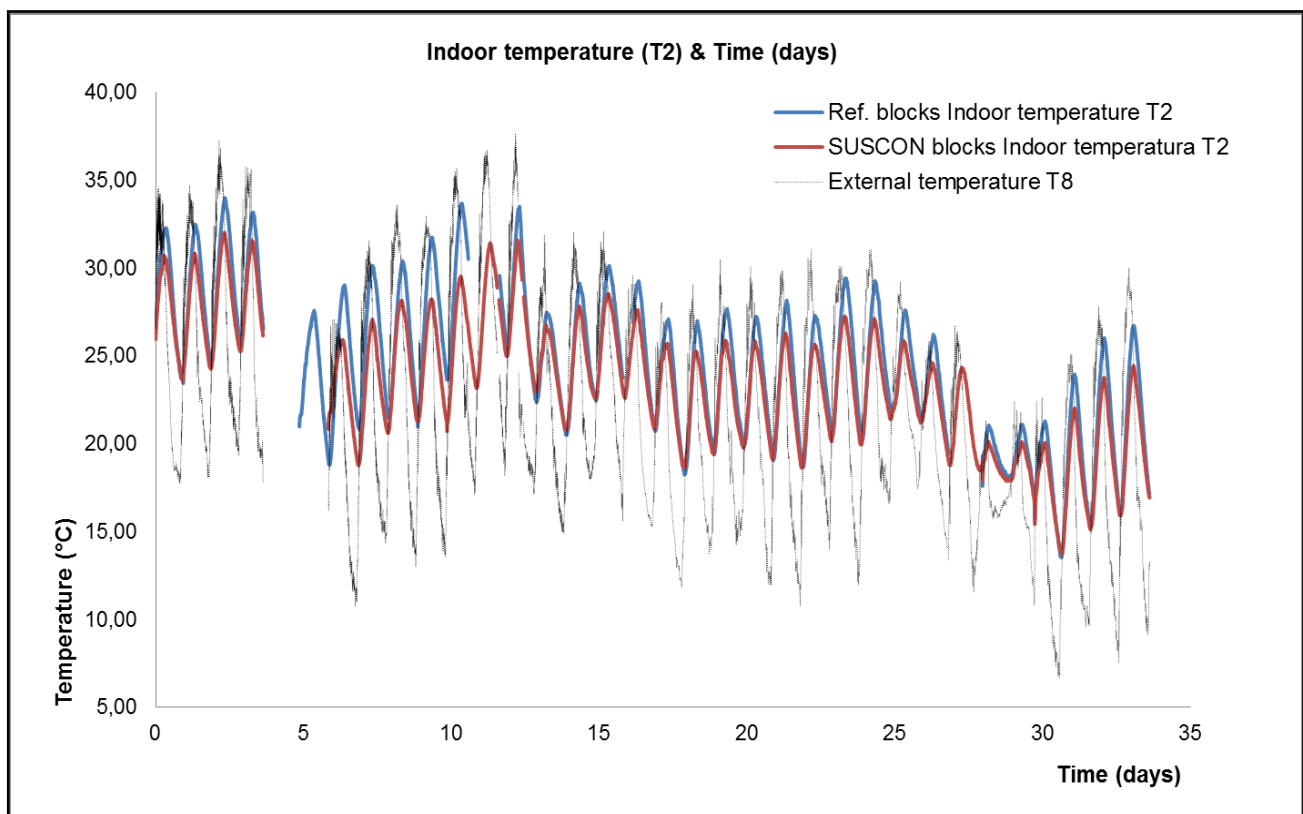

Figure 11: Charter Indoor temperature (T2) blocks mock-ups versus Time (days).

As it can be concluded from the chart, the maximum indoor temperature in the SUS-CON blocks mock-up is lower than in the Reference blocks mock-up during the day. The temperature difference was up to the 4 °C. Overnight the indoor temperature is almost the same in the two mock-ups.

Then, the indoor temperature gradient in the SUS-CON blocks mock-up is lower than in the Reference blocks mock-up, which is good from an energy efficiency point of view.

- Chart of indoor temperature on the walls (T3) in the reference blocks and SUS-CON blocks mockups versus time:

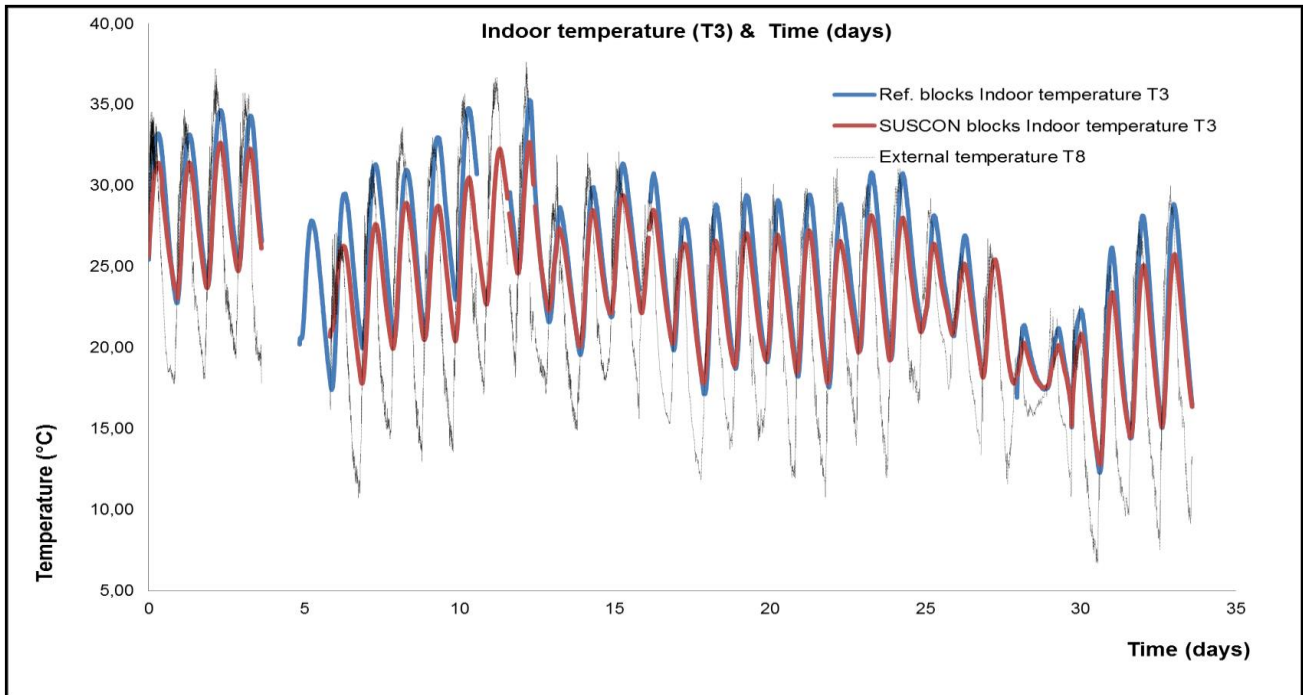

Figure 12: Charter Indoor temperature (T3) blocks mock-ups versus Time (days).

In this case, the result is similar than the indoor temperature (T2) measurements.

- Chart of indoor temperature on the walls (T3) and external temperature on the walls (T9) in the Reference blocks mockups versus time:

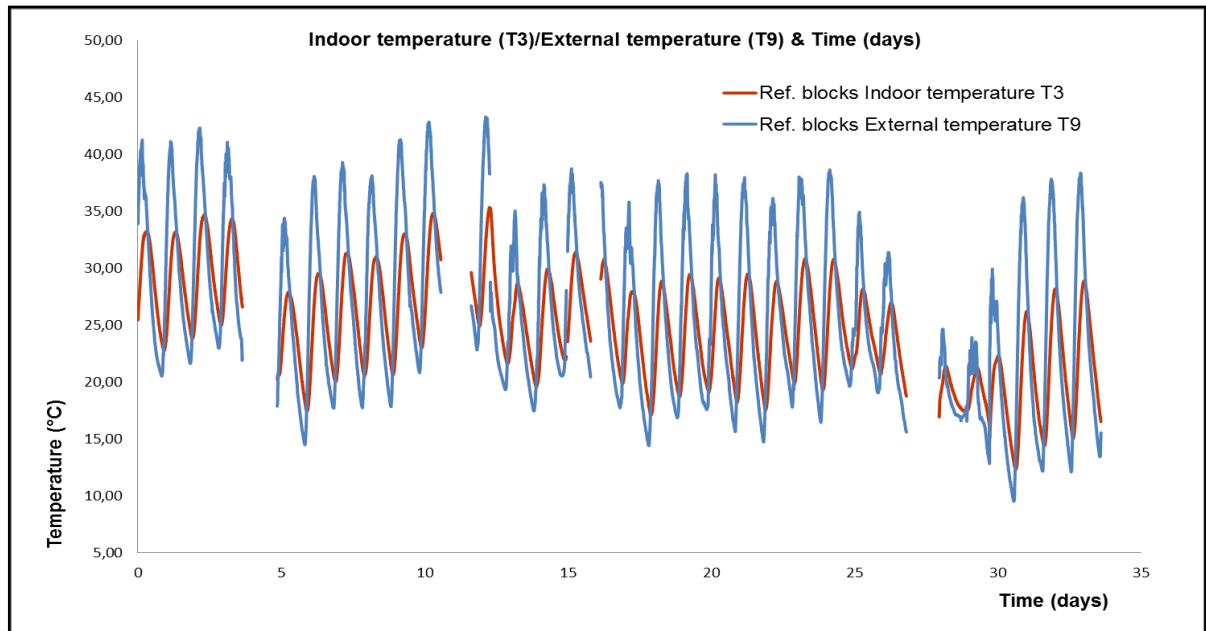

Figure 13: Charter Indoor/ external temperature (T3/T9) Reference blocks mock-up versus Time (days).

- Chart of indoor temperature on the walls (T3) and external temperature on the walls (T9) in the SUSCON blocks mockups versus time:

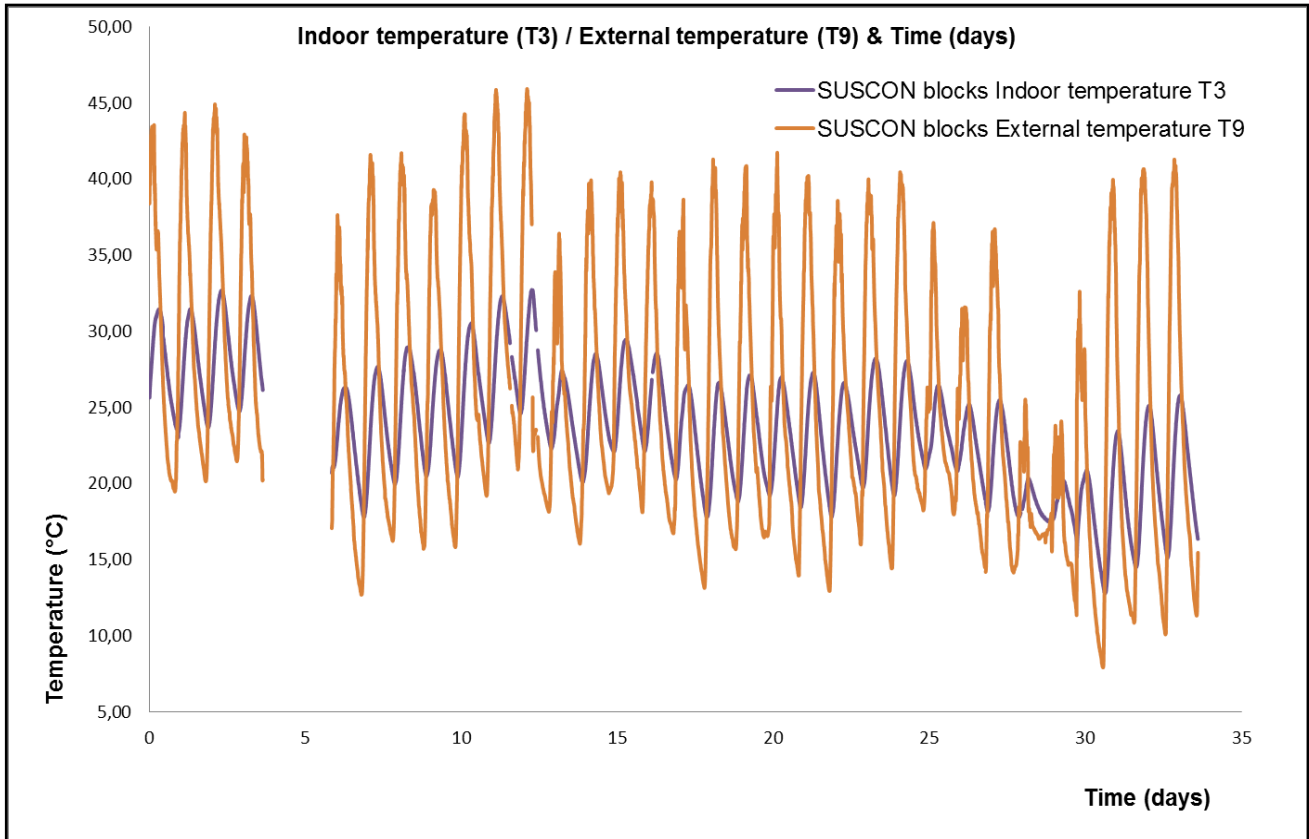

Figure 14: Charter Indoor/ external temperature (T3/T9) SUS-CON blocks mock-ups versus Time (days).

In the case of SUS-CON blocks mock-up the temperature difference between external temperature on the walls and indoor temperature on the walls is higher than in the Reference blocks mock-up. It means that in the SUS-CON blocks mock-up the temperature flux through the wall is lower than the temperature flux through the wall of the reference blocks mock-up.

- Chart of Heat flux in the reference and SUS-CON blocks mockups versus time:

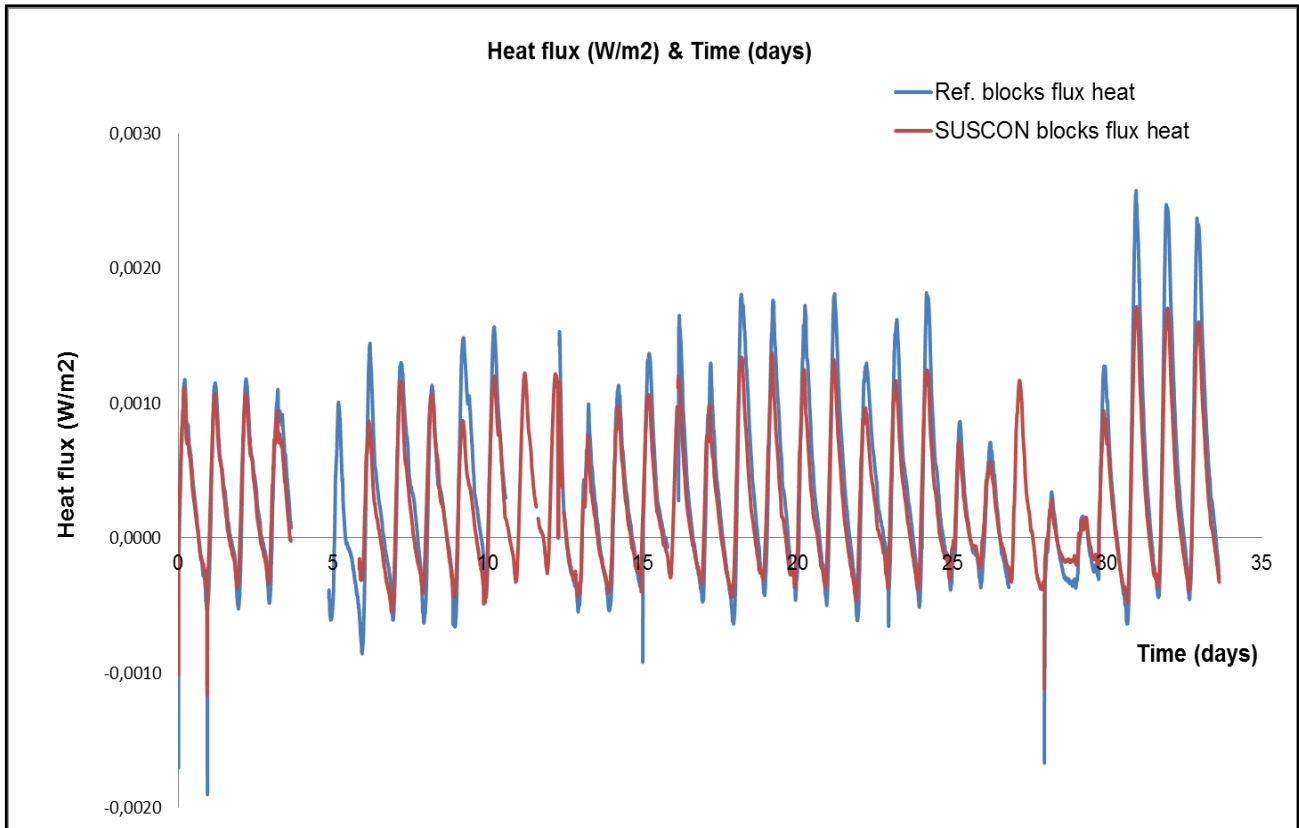

Figure 15: Charter Heat Flux (W/m^2) blocks mock-ups versus Time (days).

The heat flux reached in the SUS-CON blocks mock-up is lower than the heat flux obtained in the reference blocks mock-up. This result confirms the obtained result in the chart above where the temperature flux through the wall in the SUS-CON blocks mock-up was lower than the temperature flux through the wall of the reference blocks mock-up.

2.5.2. Panels mock-ups results

- Chart of indoor temperature (T2) in the reference panels and SUSCON panels mockups versus time:

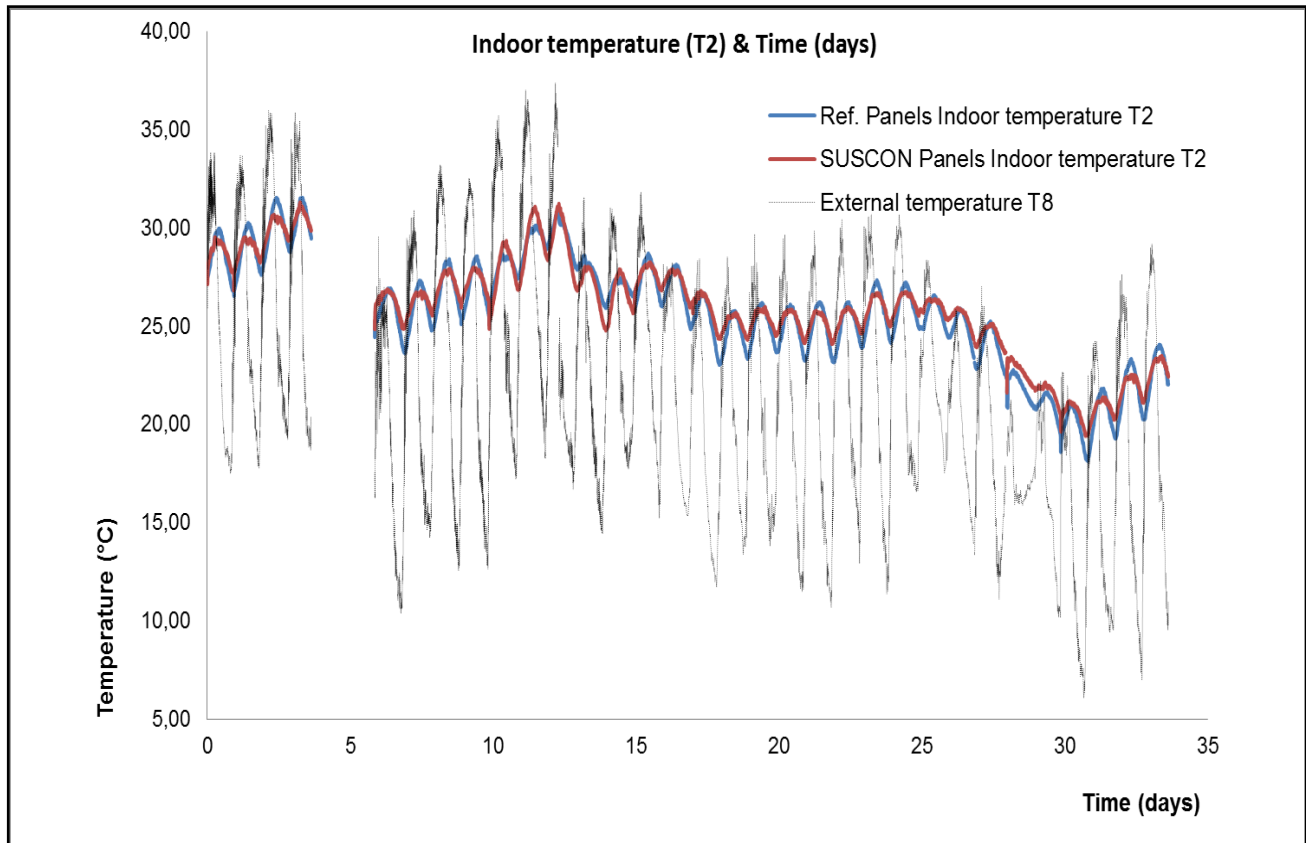

Figure 16: Charter Indoor temperature (T2) panels mock-ups versus Time (days).

The indoor temperature in the SUS-CON panels mock-up is slightly different to the indoor temperature of reference panels mock-up. During the day the indoor temperature is 0.5 °C lower in the SUS-CON panels mockup, and overnight the indoor temperature inside the SUS-CON panels mockup is 1.0-1.5 °C higher than the reference panels mockup. Both evidences are good from an energy efficiency point of view.

- Chart of indoor temperature on the walls (T3) in the reference panels and SUSCON panels mockups versus time:

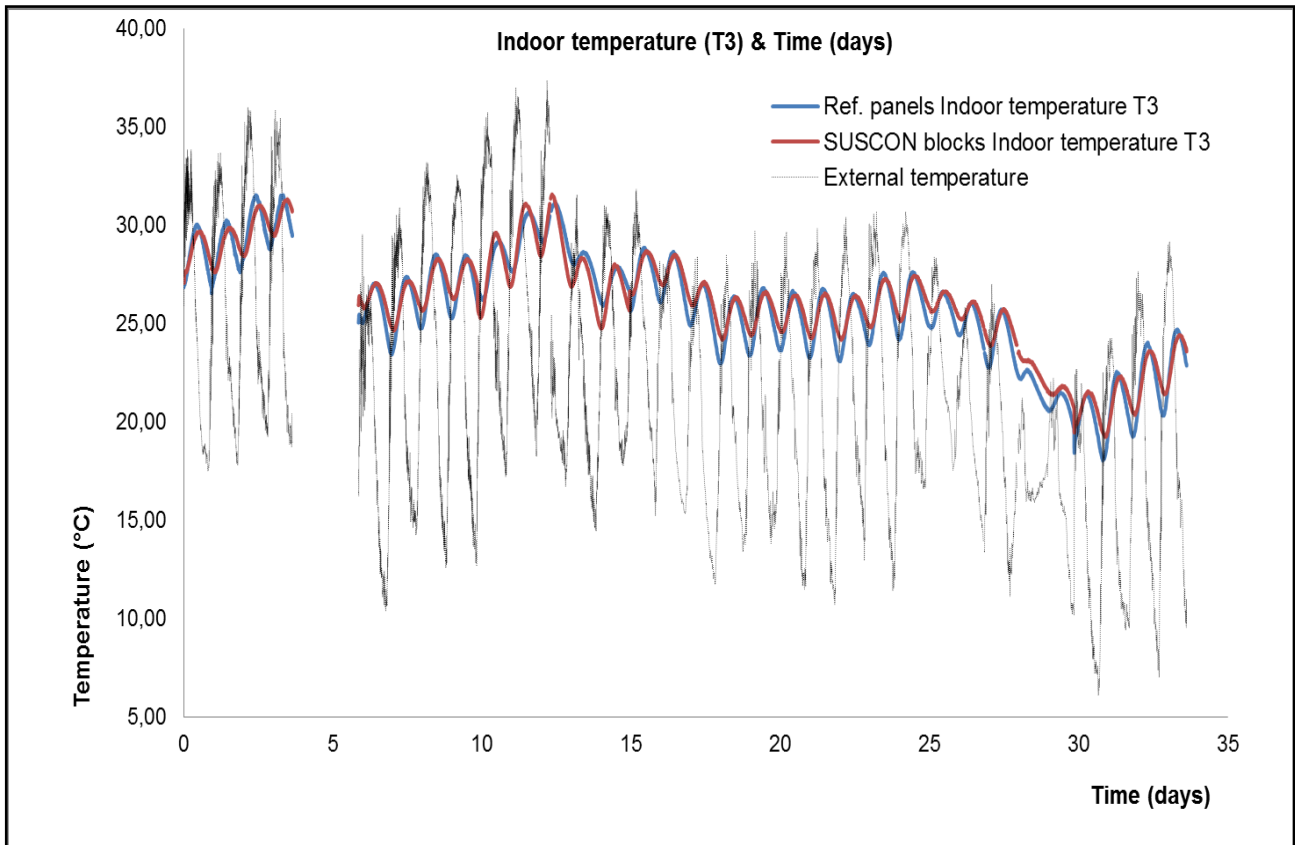

Figure 17: Charter Indoor temperature (T3) panels mock-ups versus Time (days).

In this case, the conclusion is the same such as when the indoor temperature (T2) is represented.

- Chart of room temperature on the walls (T3) and external temperature on the walls (T9) in the Reference panels mockups versus time:

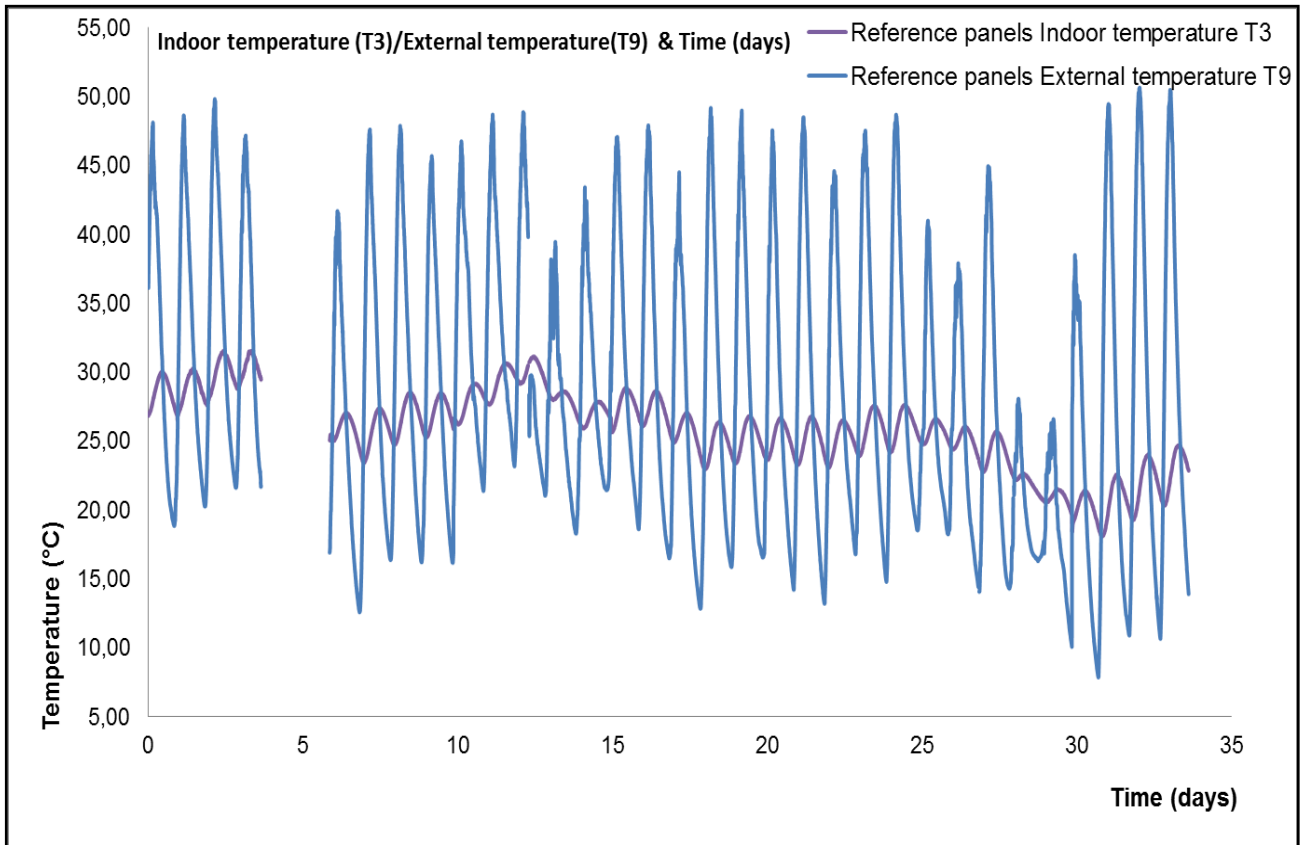

Figure 18: Charter Indoor/ external temperature (T3/T9) Reference panels mock-up versus Time (days).

- Chart of indoor temperature on the walls (T3) and external temperature on the walls (T9) in the SUSCON panels mockups versus time:

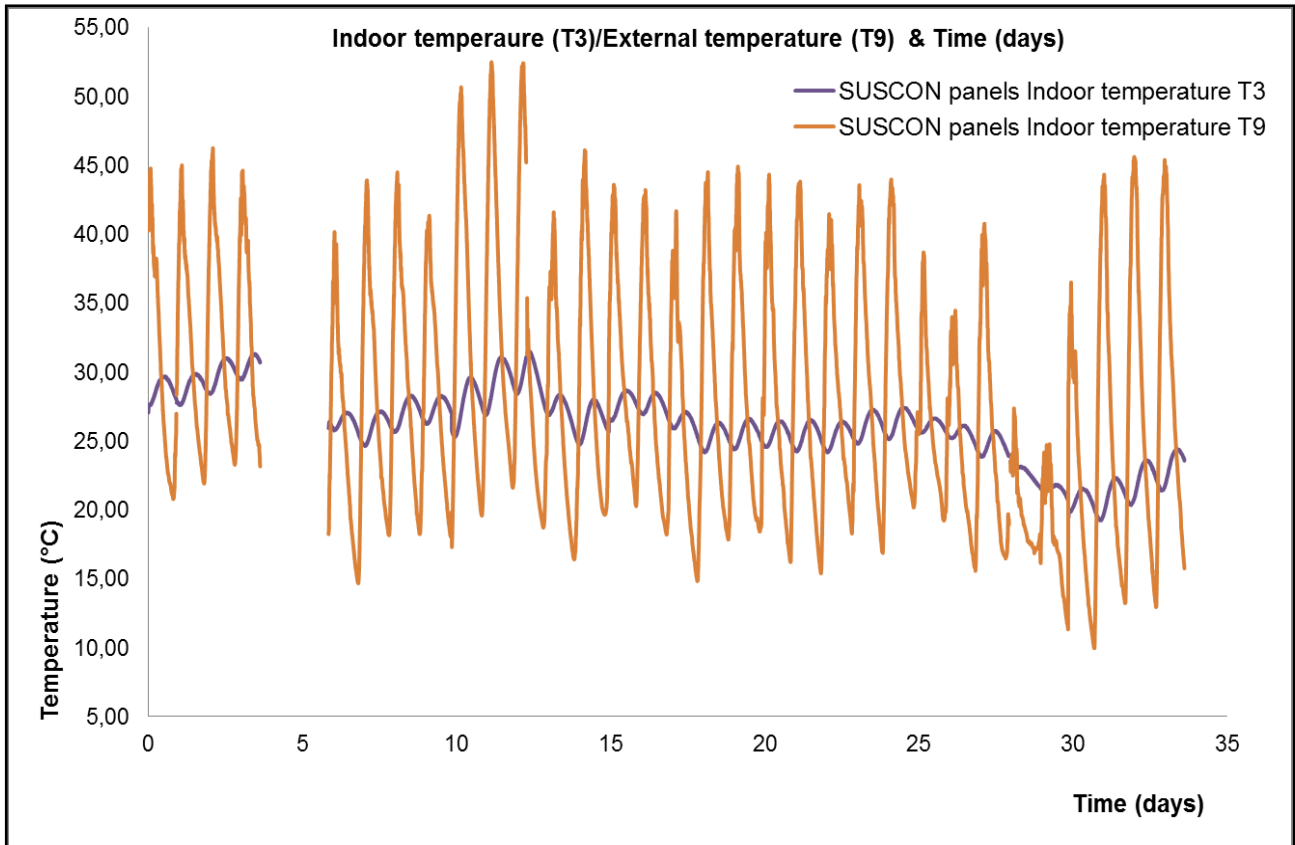

Figure 19: Charter Indoor/ external temperature (T3/T9) SUSCON panels mock-up versus Time (days).

- Chart of Heat flux in the reference and SUSCON blocks mockups versus time:

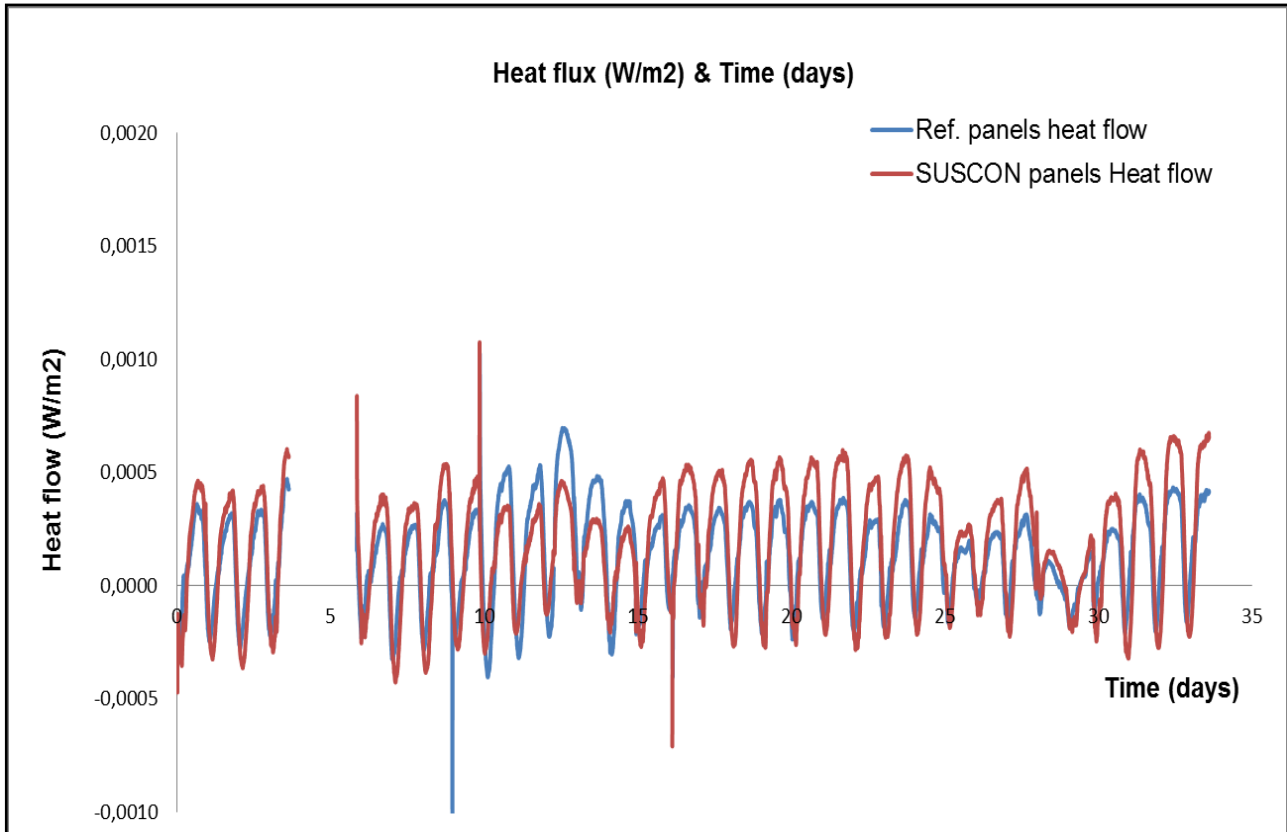

Figure 20: Charter Heat flux (W/m²) blocks mock-ups versus Time (days).

The heat flux in the SUS-CON panels mockup is slightly higher than the heat flux obtained in the reference panels mock-up, which is not consistent with the temperatures analyzed in the charts above, where the SUS-CON panels seemed to insulate more than the reference panels. This chart will be updated soon and the heat flux probes installation will be checked.

2.6. Final considerations

Taking into account all the results obtained to the date (measurements will continue till the end of SUS-CON Project and will be reported in D6.6) it can be concluded that:

- the SUS-CON blocks are lighter and their thermal insulation properties are higher than the ones of the reference blocks. This point is confirmed in the block mockups, where the SUS-CON blocks mockup is far more energy efficient than the reference



blocks mockup. The maximum indoor temperature in the SUS-CON blocks mock-up is 4 °C lower than in the Reference blocks mock-up during the day. Overnight the indoor temperature is almost the same in the two mock-ups;

- regarding the panel mockups, during the day the indoor temperature is 0.5 °C lower in the SUS-CON panels mockup, and overnight the indoor temperature inside the SUS-CON panels mockup is 1.0-1.5 °C higher than the reference panels mockup;
- in both types of mockups, the thermal inertia of the SUS-CON construction materials is lower than the one of the reference construction materials, which is good and very promising from an energy efficient point of view;
- besides, taking into account the fact that the SUS-CON materials are made of nearly 100% secondary raw materials, it can be concluded that SUS-CON materials are excellent from a sustainable point of view.

3. Description of the mock-ups in Turkey and Romania

3.1. Locations in Turkey and Romania

Two other locations will host SUS-CON demo structures that will be built with the SUS-CON products manufactured by ISTON.

- Location in Turkey:

The demo-site will be built in one of the facilities of ISTON at the Anatolian part of Istanbul. The selected area is a part of a small recreation area in the facility that ensure the duration of 3 years for the existence. The location is suitable for one reference and SUS-CON demo of 2.5x2.5m sizes. The images of the location can be seen below.

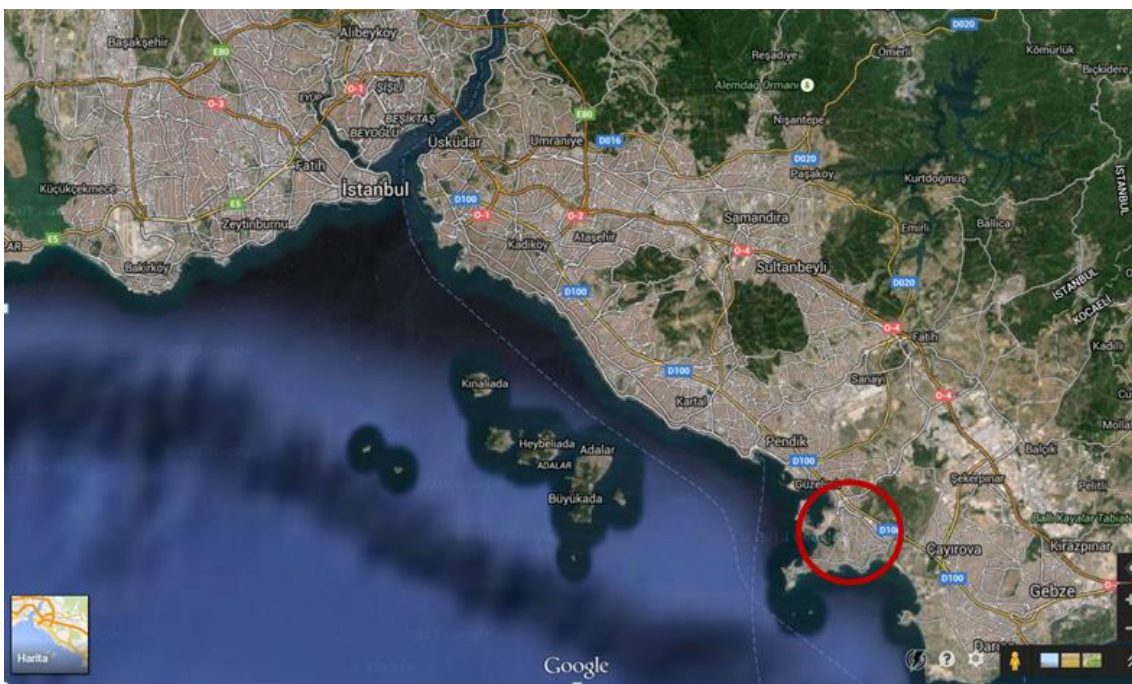

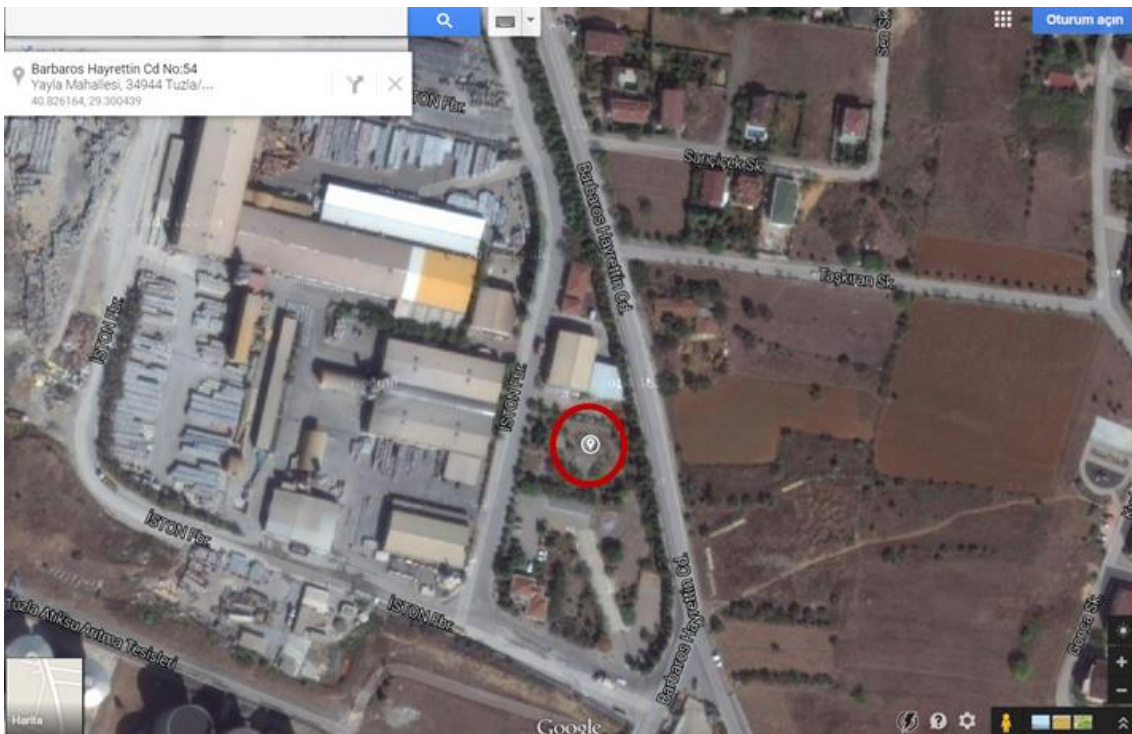



Figure 21: Location of the demo in Istanbul.

- Location in Romania:

The demo-site will be built in one of the facilities of IRIDEX in Voluntari, near Bucharest. The image of the location can be seen below.



Figure 22: Location of the demo in Bucharest.

3.2. Design of the mockups in Turkey and Romania

ISTON will also produce SUS-CON façade panels and building blocks following its own design in order to provide the materials needed to construct the demo structures in Turkey and in Romania.

Blocks

Current kerb molds of 70x35x15 cm were selected for block production. These molds are suitable to be used in conventional methods including strong table vibrators. Some sketches of the molds can be seen below.

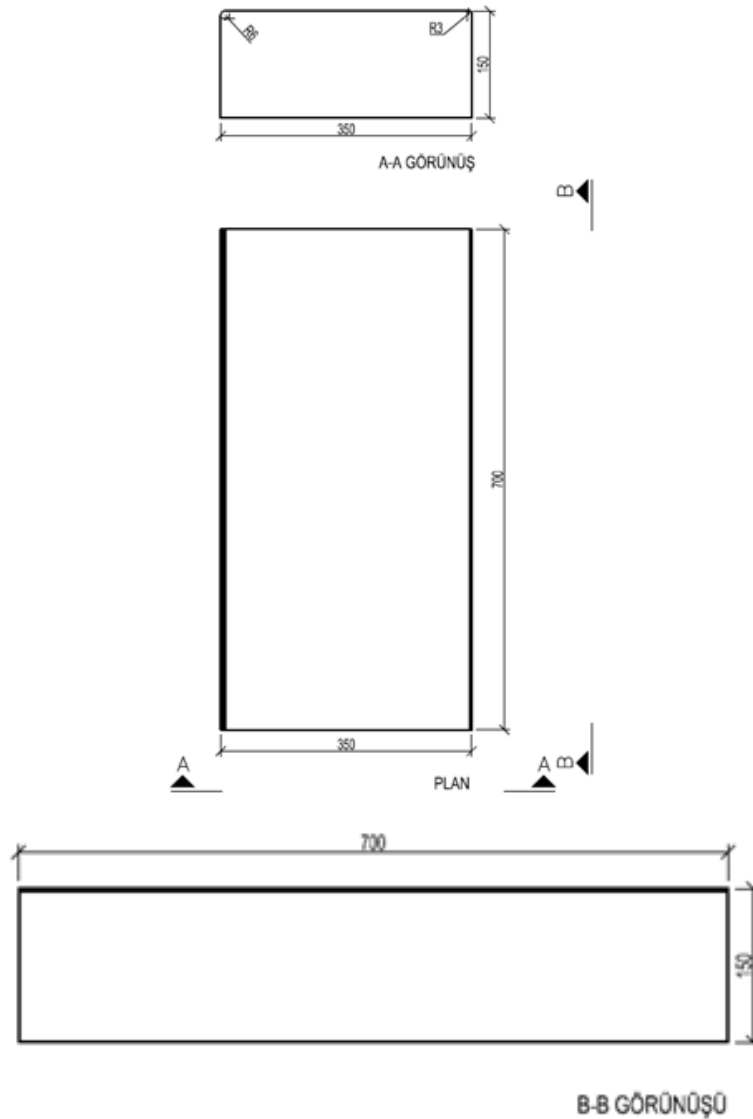

Figure 23: Sketches of the block mold.

Panels and mock-up

Wooden molds for the production of panels were produced. The molds will be modified in order to produce walls different dimensions. The sketches of the mock up and panels can be seen in the figure below.

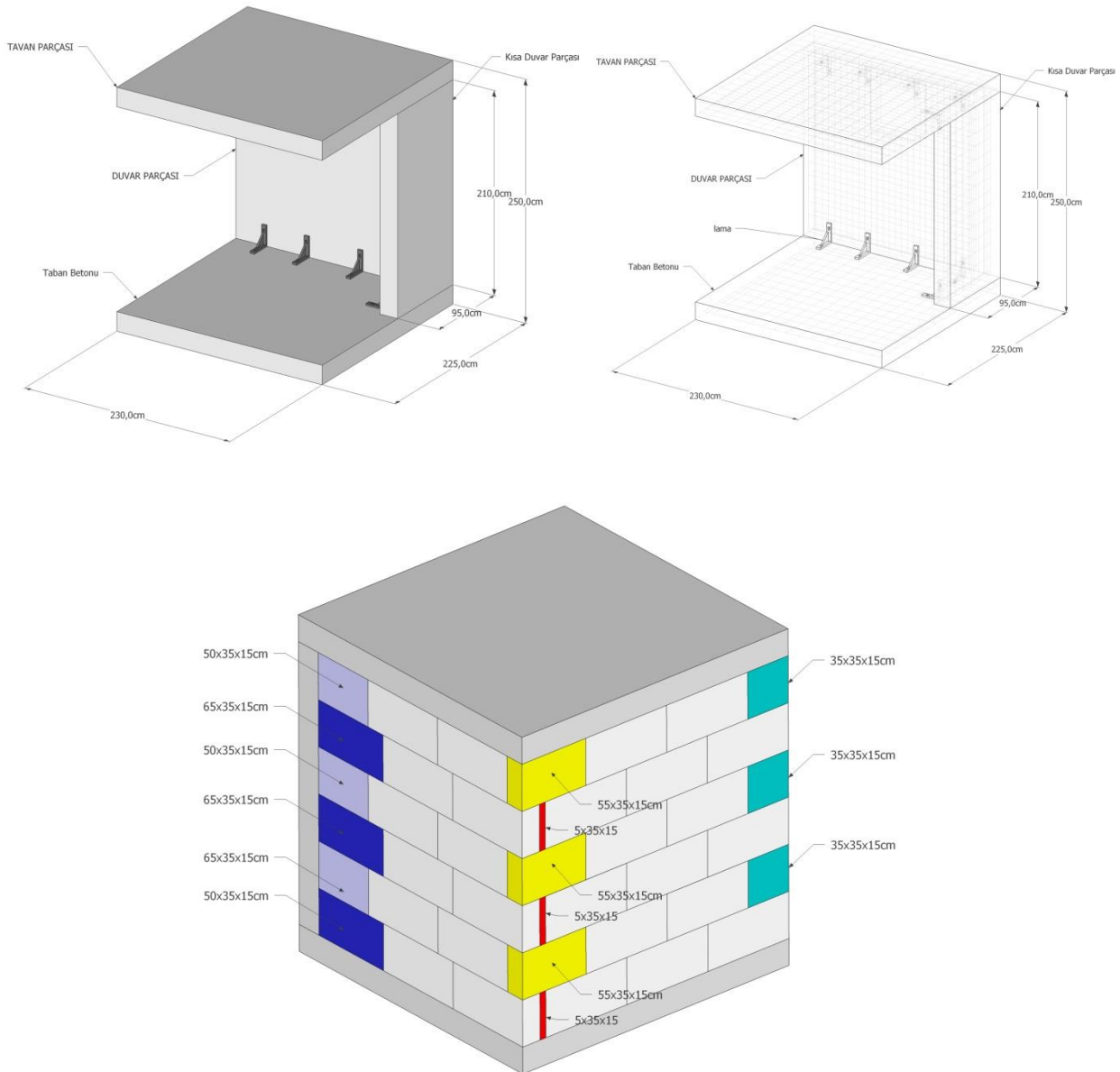

Figure 24: General view.

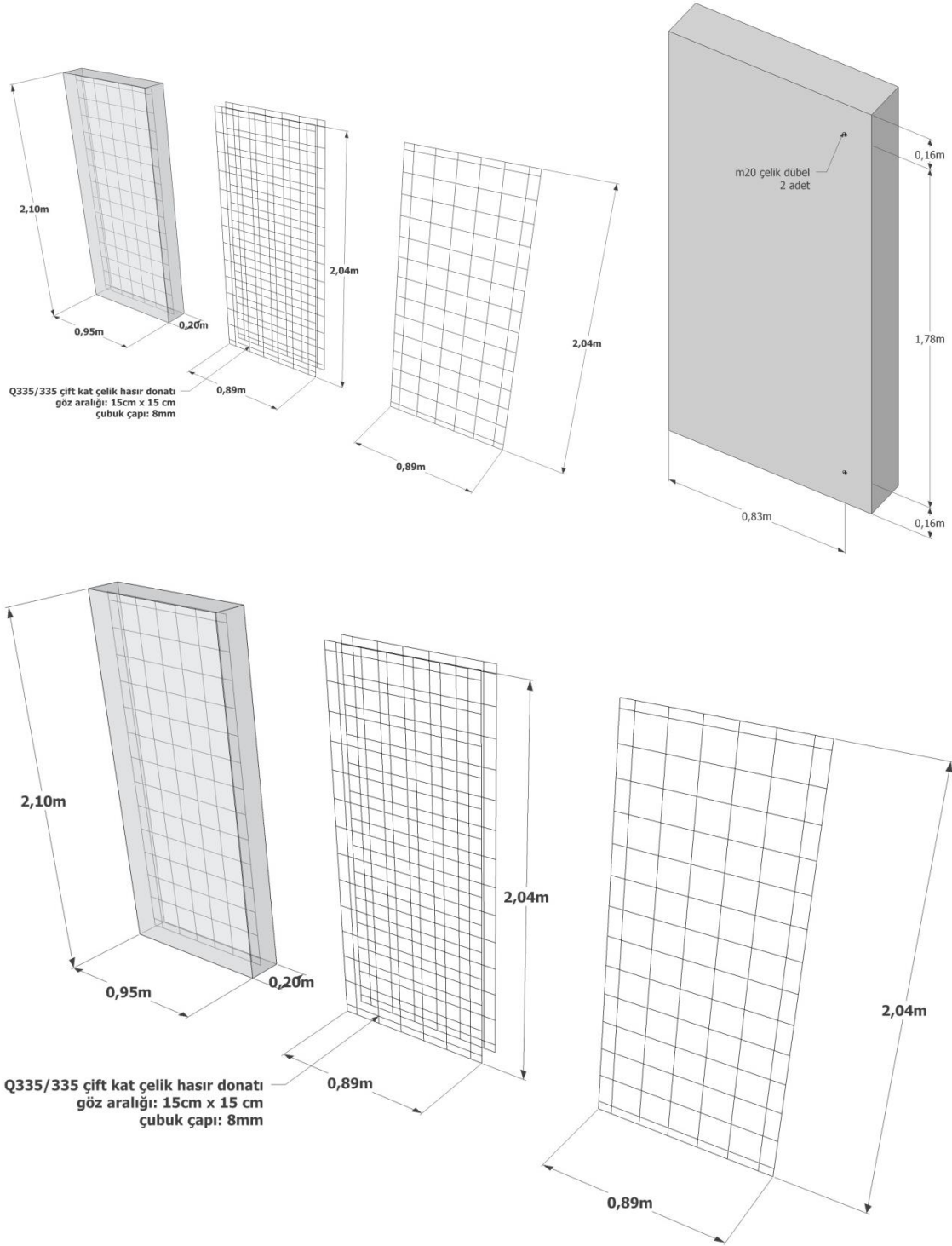

Figure 25: Sketches of the short wall.

R PARÇASI

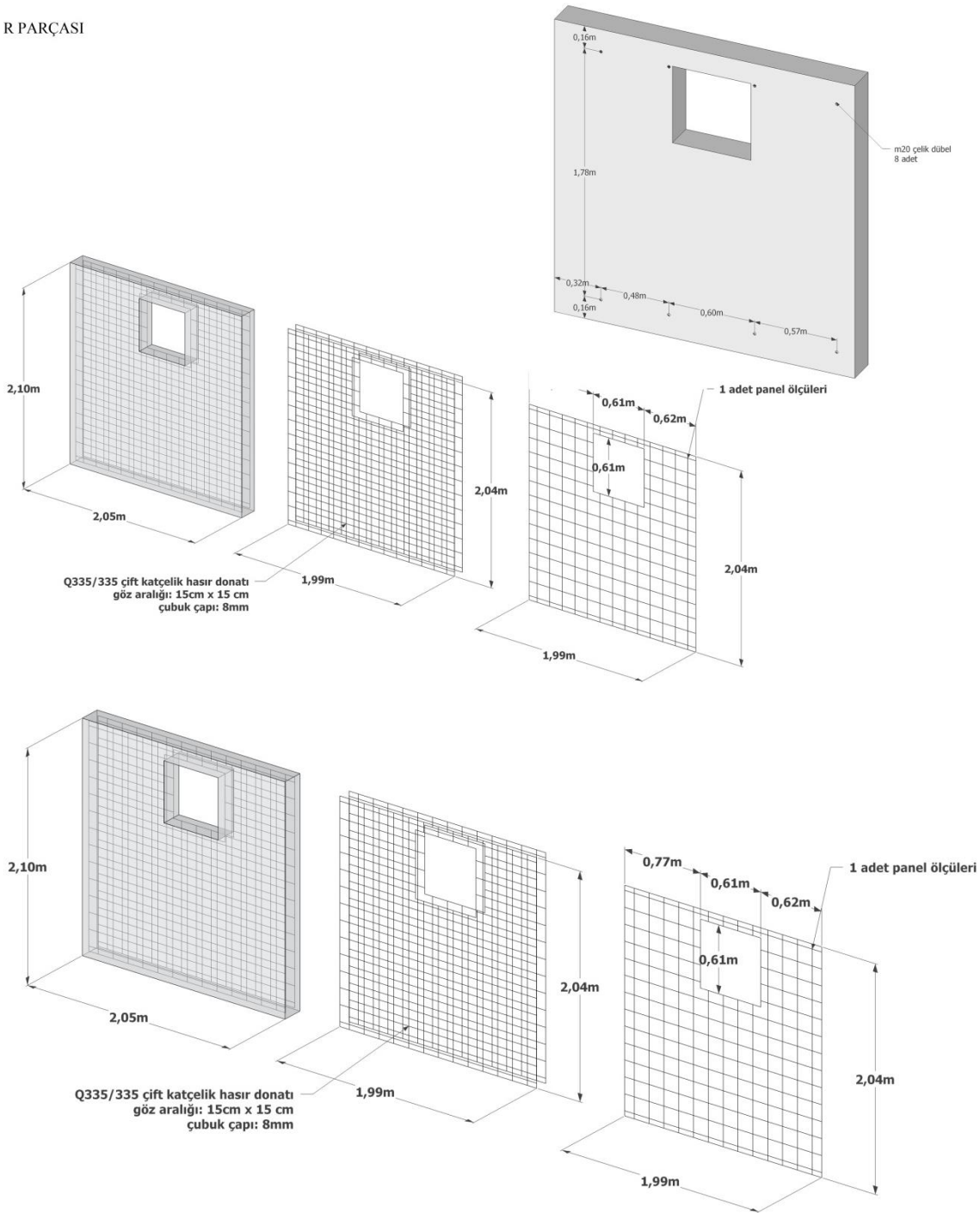
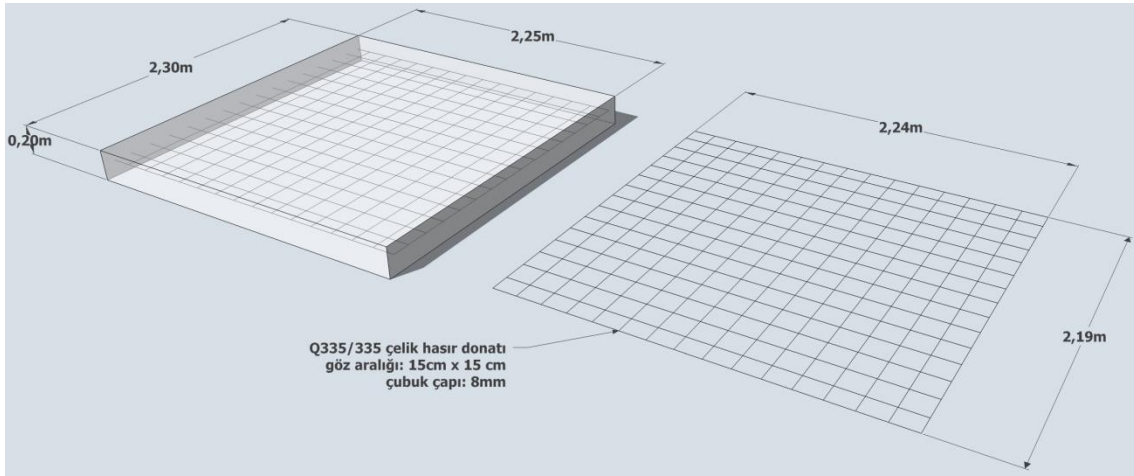

Figure 26: Sketches of the side wall.

It is planned to use screed mixes in the slab and panel mixes to produce roof element. Assembling will be made with anchorages of 20 mm steel plate and M24 bolts.



RÇASI

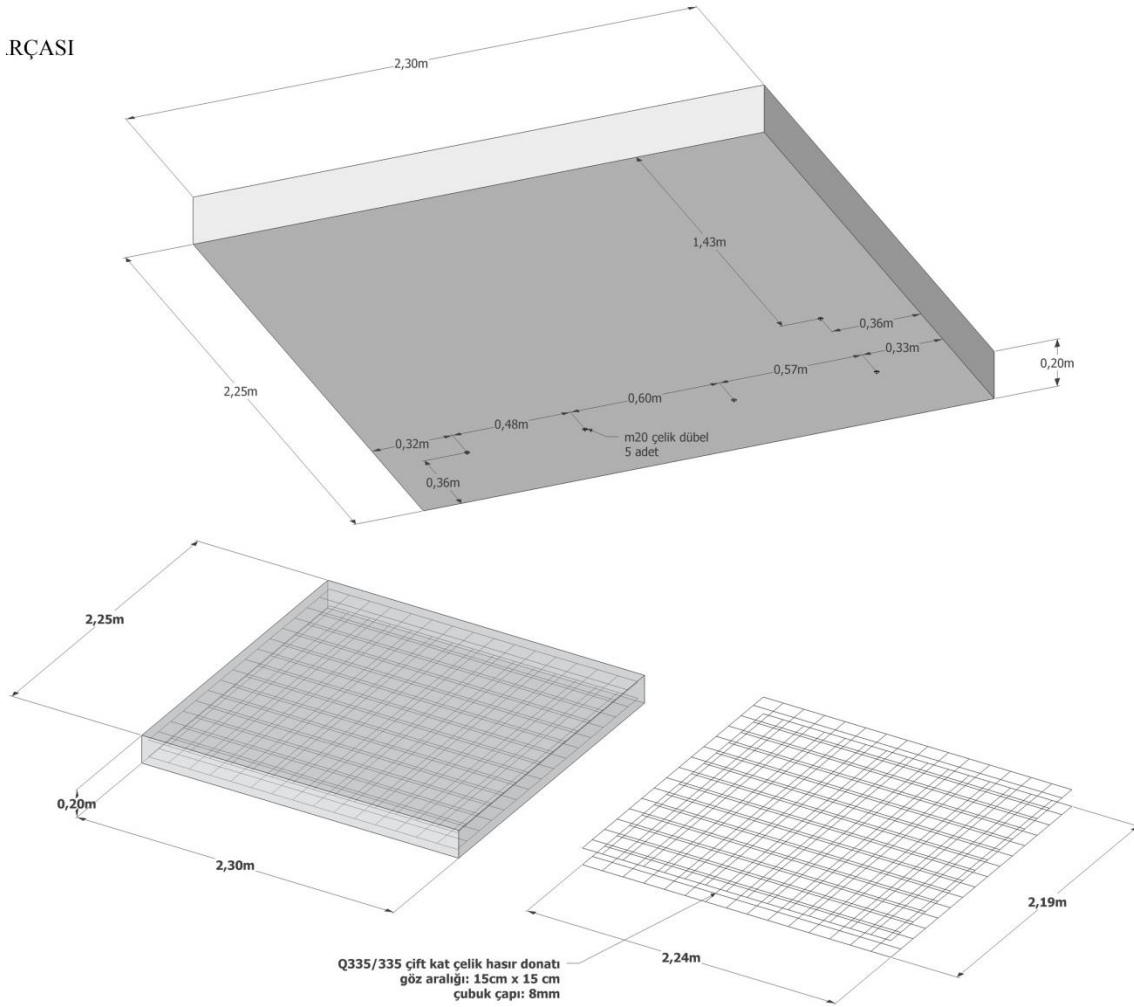

Figure 27: Sketches of roof and slab elements.

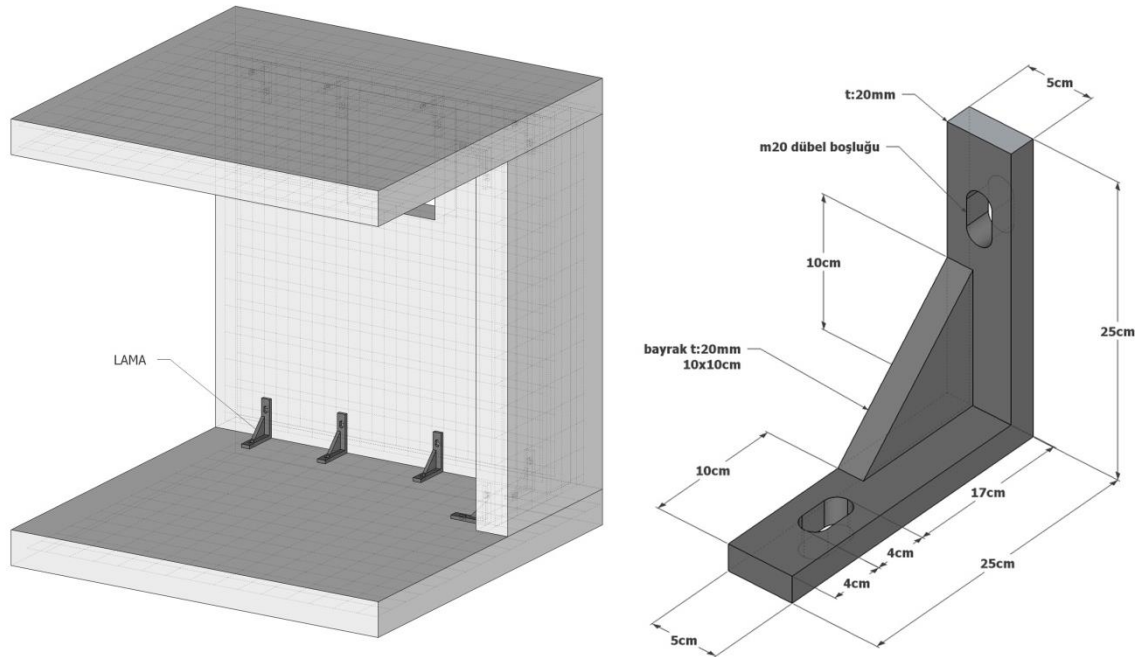

Figure 28: Sketches of anchorages.

3.3. Materials

According to the outputs from WP4 ISTON will produce mixes containing Remix and PU aggregates, sodium silicate and sodium hydroxide solutions, PFA and GGBS as binders. Since the import of PFA and GGBS material is prohibited in Turkey, ISTON searched for local sources. Some local sources were selected taking into account some properties that are key parameters for geopolymeric activity:

- content of SiO_2 and Al_2O_3 ;
- fineness;
- lower CaO content;
- loss of ignition;
- glass content.

For the PFA, Sugözü Power Station was selected as primary source. The plant is located in the south of Turkey and has 1210 MW (2X605) net installed capacity. PFA of Sugözü plant is F type because of the bitumen coal and anthracite. In the next table the updated analysis report of the PFA is given.

Sugözü PP  İSKENDERLİN ENERJİ ÜRETİM VE TİCARET A.Ş.	QUALITY CONTROL REPORT FOR FLY ASH UÇUCU KÜL KALİTE KONTROL RAPORU 20302-T-04-F-09	 TÜRK AKAS TÜRK AKAS AKAS	Page/Sayfa No..... 1
			Total / Toplam Sayfa1
			Revision / Revizyon No - 1 -

Dönem / Period : Mart / March 2015

Day Gün	Remarks Açıklamalar	Particle density Tanecek Yoğunluğu (kg/m ³)	Activity Index Aktivite Endeksi		Soundness Genleşme (mm)	Fineness* (> 45µm) İncecik (%)	LOI* Kızdırma Kaybı (%)	SiO ₂ (%)	Al ₂ O ₃ (%)	Fe ₂ O ₃ (%)	Total Toplam CaO (%)	SO ₃ (%)	Alkalis Alkaller Na ₂ O (%)	Free Serbest CaO (%)	Cl ⁻ (%)
			28 days 28 gün (%)	90 days 90 gün (%)											
Su / Pzr. 1						16,7	2,65								
2						18,0	2,35								
3		2250	80,7	90,9		15,5	2,12	57,74	24,35	6,08	2,55	0,25	1,80	0,107	0,020
4						21,2	2,25								
5						18,4	2,38								
6						17,1	1,47								
Sa / C.tsi 7						16,1	2,17								
Su / Pzr. 8						15,4	2,29								
9						11,4	2,22								
10						23,4	2,21							0,101	
11						18,1	2,30								
12						17,2	1,93								
13						16,7	2,31								
Sa / C.tsi 14						17,7	2,14								
Su / Pzr. 15						18,9	2,10								
16		2280	77,9	92,4		18,1	1,97								
17						16,7	2,07							0,053	
18						17,4	1,73								
19						18,8	1,97								
20						18,6	1,80								
Sa / C.tsi 21						20,1	2,15								
Su / Pzr. 22						20,1	1,90								
23						16,4	1,57								
24						15,6	1,66							0,051	
25						18,9	2,24								
26						16,0	2,25								
27						19,0	1,97								
Sa / C.tsi 28						17,4	2,08								
Su / Pzr. 29						17,7	2,21								
30						19,4	2,63								
31						14,1	1,80							0,137	

According to EN 450-1 / EN 450-1 e göre

Limit values / limit değerler	2350 ± 200	> 75	> 85	< 10	16 ± 10	< 5	SiO ₂ +Al ₂ O ₃ +Fe ₂ O ₃ > 70			< 3	< 5	< 1,5	< 0,1
Minimum analysis period / Minimum analiz periyodu	1/month 1/ay	2/month 2/ay	2/month 2/ay	..	1/day 1/gün	1/day 1/gün	1/month 1/ay	1/month 1/ay	1/month 1/ay	1/month 1/ay	1/week 1/hafta	1/month 1/ay	
Statistics / İstatistikler	2280	80,70	92,40	--	23	2,65	57,74	24,35	6,08	2,55	1,80	0,137	0,020
max	2280	80,70	92,40	--	23	2,65	57,74	24,35	6,08	2,55	1,80	0,137	0,020
min	2250	77,90	90,90	--	11	1,47	57,74	24,35	6,08	2,55	1,80	0,053	0,020
average	2265	79,30	91,65	--	18	2,09	57,74	24,35	6,08	2,55	1,80	0,092	0,020
std	21,21	1,98	1,06	--	2,20	0,27	--	--	--	--	--	0,03	0,020
n	2	2	2	--	31	31	1	1	1	1	1	5	1

Figure 29: Properties of Sugözü PFA.

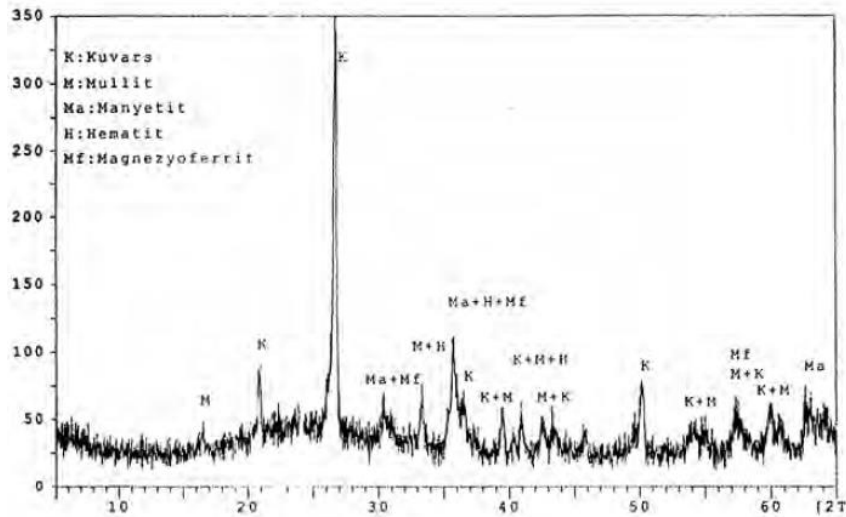



Figure 30: X-ray diffractogram of Sugözü PFA.

Bolu GGBS was selected as the local source. The chemical composition and physical properties of the material are similar with the reference product. However, the glass content of the GGBS is 100%.

		ANALİZ RAPORU (ANALYSIS REPORT)							
NUMUNE (SAMPLE)	CİNSİ (TYPE) : ÖĞÜTÜLMÜŞ YÜKSEK FIRIN CÜRUFU (GROUND GRANULATED BLAST FURNACE SLAG)								
	STANDARDI (STANDARD) : TS EN 15167-1								
	YERİ (TAKEN FROM) : PAKETLEME (PACKING UNIT)								
	ALINDIĞI TARİH (DATE) :								
KİMYASAL ANALİZLER (%) (CHEMICAL ANALYSIS)		Standart (Standard)	Analiz Sonucu (Analysis Result)	FİZİKSEL ANALİZLER (PHYSICAL ANALYSIS)		Standart (Standard)	Analiz Sonucu (Analysis Result)		
	SiO ₂		40,00		Özgül Ağırlık (Specific Gravity)	gr/cm ³		2,86	
	Al ₂ O ₃		12,80		Su İhtiyacı (Water Demand)	%			
	Fe ₂ O ₃		1,00		Referans (Reference)	Dakika (minute)		150	
	CaO		35,50		Priz Başı (In. set. time)	Dakika (minute)	max. (2xRef.)	180	
	MgO	max. 18,00	7,00		Karışım (Mixture)	Dakika (minute)			
	SO ₃	max. 2,50	0,15		Şatölye (Soundness)	mm		1,0	
	Na ₂ O		0,60		Özgül Yüze (Specific Surface)	cm ² /gr	min. 2750	4800	
	K ₂ O		1,00		İncelik (Fineness)	Elek Üstü (Residue)	45 µ	%	1,5
	Toplam Alkali (Total Alkali)		1,26		Hidrasyon Isısı (Hydration Heat)	cal/gr			
	Cl ⁻	max. 0,1000	0,0100	MİNERALOGİK KOMPOZİSYON (MINERALOGICAL COMPOSITION)	C ₃ S	%			
	S ²⁻	max. 2,00	0,70		C ₂ S	%			
	Cr ⁺⁶ ppm				C ₃ A	%			
	TiO ₂		1,00		C ₄ AF	%			
	Mn ₂ O ₃		0,50		2C ₃ A+C ₄ AF	%			
	Kızdırma Kaybı (Loss on Ignition)	max. 3,00	0,10		Kireç Standartı (Lime Saturation Factor)	%			
	Çözünmeyen Kalıntı (Insoluble Residue)			s.CaO (f.CaO)	%				
	Katkı Miktarı (Additive Amount)			MEKANİK TESTLER (MECHANICAL TESTS)	GÜN (DAY)		AKTİVİTE, % (ACTIVITY)		
	(CaO + MgO) / SiO ₂	min. 1,00	1,06		1				
	CaO + MgO + SiO ₂	min. 66,67	82,50		2				
Camsı Faz (Glass Content)		100,00	7		min. 45,0	50,0			
Rutubet (Moisture)	max. 1,00	0,10	28		min. 70,0	75,0			
			GÜN (DAY)			EĞİLME DAYANIMI, MPa (FLEXURAL STRENGTH)			
			28						
					Kal. Kont.ve Yön. Md. (Q.C. and Management Manager)				
									

Lab.F-10/22.07.2013/04

Figure 31: Properties of Bolu GGBS

3.4. Final considerations

In this section, the status of activities related to mock-ups in Turkey and Romania have been reported. The activities have a small delay, with respect to the mock-ups in Spain, due to the need of binders procurement from different sources.



Currently all the necessary materials have been procured, the design of components and relevant mock-ups have been defined. In the following months, the components (blocks, panels and screeds) production and building of demo sites will be completed.

All these activities, including some preliminary lab trials and tests necessary before the implementation of these concretes in the plant, will be detailed in the next report (D6.6).



4. General conclusions

The aim of the Project to have a new technology that integrates secondary raw materials for ready-mixed and pre-casted applications - resulting in innovative, light-weight, eco-compatible and cost-effective concretes with low embodied energy, CO₂ and improved thermal insulation performances - was demonstrated with the outcomes reported in this document.

D6.4 mainly concerns with the activities related to the construction and monitoring of mock-ups in Spain. SUS-CON concrete elements (i.e. panels and blocks), made with secondary raw materials and produced by MAGNETTI, have been assembled into demo structures by ACCIONA. The storage, the transport, the manipulation and the construction with the SUS-CON products did not require any special or extra efforts from the parts involved, being the behaviour of the products similar to the traditional ones. The mock-ups were tested in terms of energy efficiency (tests are still in progress) and it was demonstrated that they behave better than traditional concrete elements assembled into similar structures.

In addition, this document reports on the status of activities related to the construction of two other mock-ups, respectively in Turkey and Romania (partners responsible ISTON and IRIDEX). This work is currently in its early stage due to some delays in the procurement of binders from different sources than those experimented in the Project. Once the SUS-CON elements that ISTON is producing will be completed and the other two mock-ups will be finalized all the goals of Task 6.4 will be finally achieved. Hence following this report, D6.4, another report, D6.6, will be issued to present the work done for the last two demonstrators together with an update about monitoring tests on demonstrators in Spain.